

PIPING CONNECTIONS FOR DIESEL FIRE PUMP CONTROLLERS

MASTER

PIPING CONNECTION FOR AUTOMATIC PRESSURE SWITCH

(PER NFPA 20 FIG. A.4.32(a))

WHERE WATER PULSATIONS CAUSE ERRATIC OPERATION OF PRESSURE SWITCH OR RECORDER A SUPPLEMENTAL AIR CHAMBER OR PULSATION DAMPER (ACCUMULATOR) MAY BE NEEDED.

NOT LESS THAN 1/2" (1.3cm) NOM. (AMERICAN TRADE SIZE) BRASS PIPE WITH BRASS FITTINGS OR EQUIVALENT.

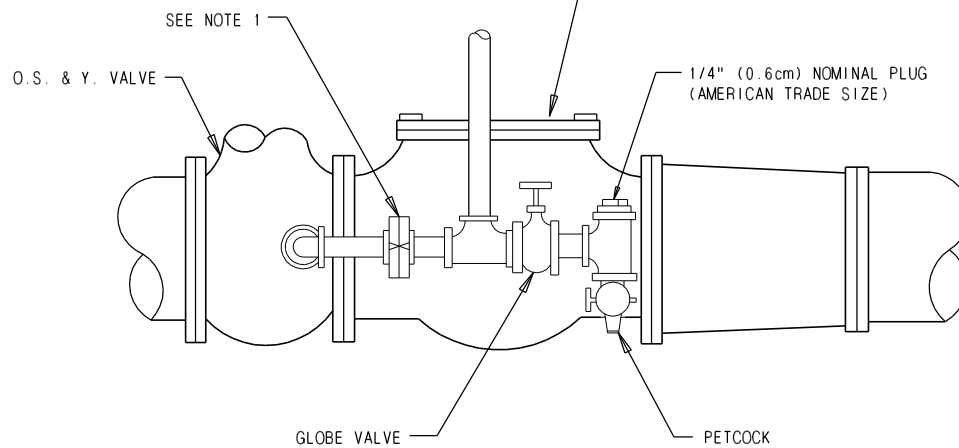
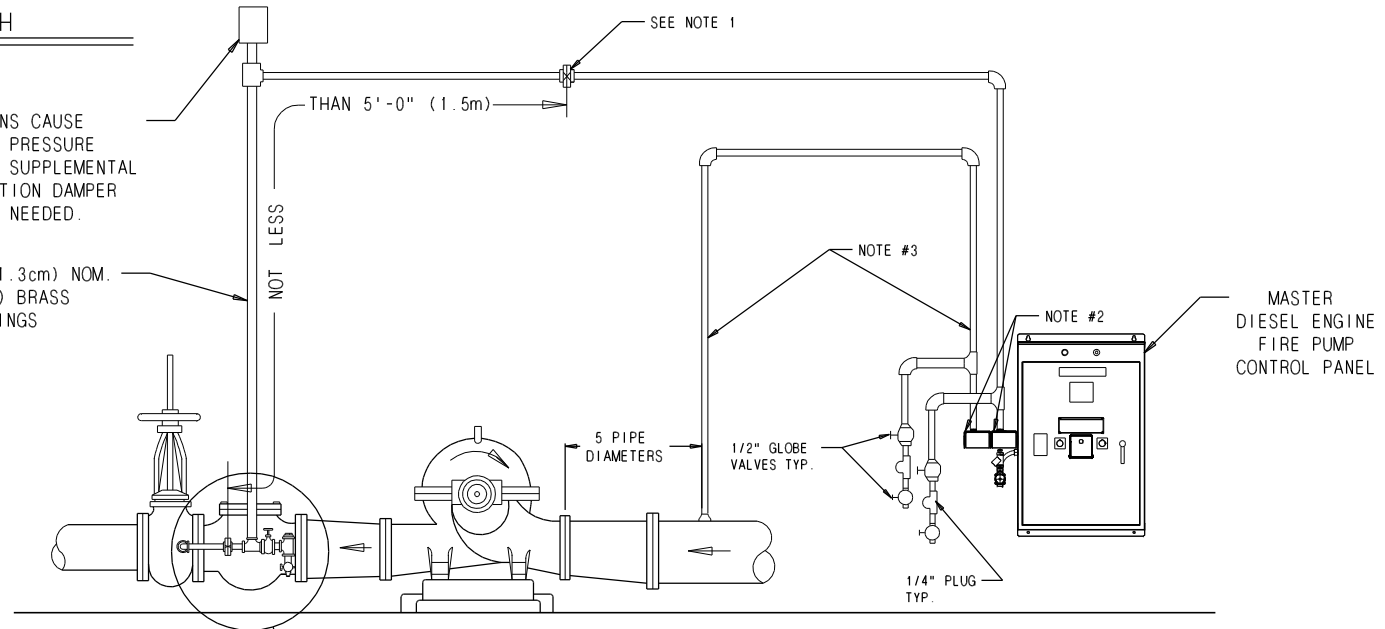

NOTE

1. BRONZE CHECK VALVES, CLAPPER DRILLED WITH 3/32" (.24 mm) HOLE, EXCEPT WHERE WATER IS CLEAN GROUND FACE UNIONS WITH NON-CORROSIVE DIAPHRAM & 3/32" (.24 mm) ORIFICE MAY BE USED.
2. 1/2" (1.3cm) NOMINAL AMERICAN STANDARD TAPER FEMALE PIPE THREAD INLET & OUTLET.
3. ADDITIONAL PLUMBING REQUIRED IF MOD. 83LT PROVIDED



Master Control Systems Inc.
LAKE BLUFF, ILLINOIS U.S.A.

Piping Connections for Diesel Controllers w/ 83LT

Date 10 September 2021

Drawing 22890 Issue 4